

**THROUGH FRAME
INSTALLATION**

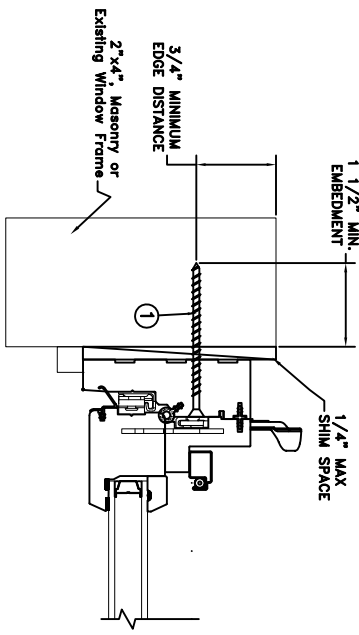
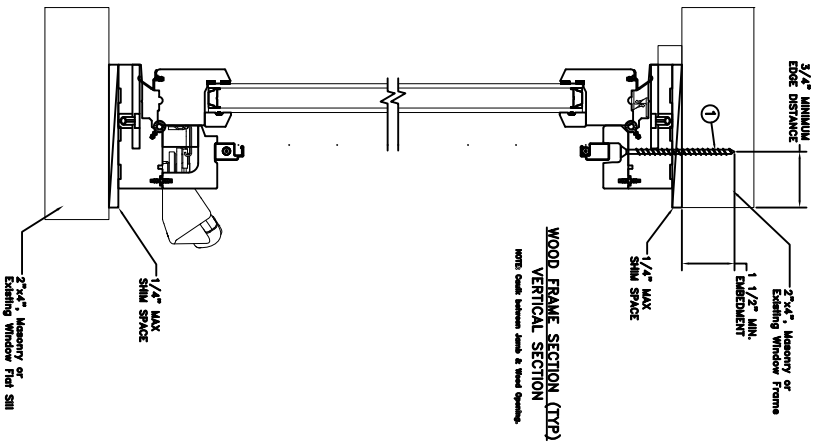

**WOOD FRAME SECTION (TYP)
HORIZONTAL SECTION**
NOTE: Gasket between Jamb & Wood Opening.

Max Frame	DP	IMPACT
48 x 48	+50 / -55	NO

TYPICAL ELEVATION WITH FASTENER SPACING

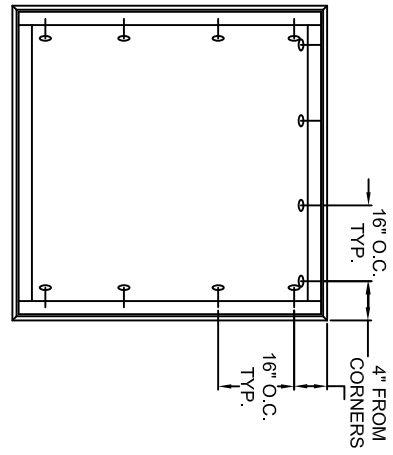

- Installed Fastener Schedule:**
1. All windows: install corrosion resistant #8 fasteners no more than 4" from each corner and 16" o.c. through pre-drilled holes in the head and side jambs of the window.
 2. Fasteners must be long enough to penetrate at least 1-1/2" into framing members.

- General Notes:**
1. The product shown herein is designed and manufactured to comply with the current edition of the Florida building code.
 2. Buck, framing and masonry by others and is responsibility of architect or engineer of record
 3. All glazing shall conform to ASTM E1300.

This schedule addresses only the fasteners required to anchor the unit to achieve the rated design pressure and impact performance (where applicable) up to the size limitations noted. It is not intended as a guide to the installation process and does not address the sealing consideration that may arise in different wall conditions. For the complete installation procedure, see the instructions packaged with the unit or go to www.jeld-wen.com.

DISCLAIMER:
This drawing and its contents are confidential and are not to be reproduced or copied in whole or in part or used or disclosed to others except as authorized by JELD-WEN Inc.

DATE:	05/18/2018
DRAWN BY:	J.HAWKINS
CHECKED BY:	K.CAMPBELL
APPROVED BY:	D.STOKES
PART/PROJECT No.:	D015231
IDENTIFIER No.:	-

DATE: 05/18/2018
SCALE: NTS
TITLE: Siteline Wood Pocket Awning

JELD-WEN
3737 LAKEPORT BLVD.
KIAMATH FALLS OR, 97601
PHONE: (800) 535-3936

CAD DWG. No.: SitelineWDPKTawn Cert
REV: A
SHEET